

Computer Programming Fundamentals

CS 152

Professor: Leah Buechley

TAs: Melody Horn, Noah Garcia, Andrew Geyko, Juan Ormaza

Time: MWF 10:00-10:50am

https://handandmachine.cs.unm.edu/classes/CS152_Fall2021/

**ASSIGNMENT 7
DUE WEDNESDAY**

FINAL EXAM

- 3 hours to complete exam
- 48 hour window
- 10am Monday 12/13 - 10am Wednesday 12/15
- 10% of final grade

THIS WEEK: REVIEW

CLARIFICATION, CHEATING

- Test is open IntelliJ. Use it to write code, check answers, etc.
- Test is open internet. You can use the internet to help you solve challenges.
- This is an individual exam. Work should be entirely your own.
- Do not copy and paste code you find on the internet.
- No assistance from me, TAs, friends, or classmates for this exam
- Do not help or write code for anyone else for this exam
- I am grading the exam

EXAM TOPICS OVERVIEW

- Programming process: write, compile execute
- Variables
- Type
- Conditionals: if, else statements
- Boolean operations
- Loops: while and for
- Methods
- CS coordinate system
- Generating random numbers
- Arrays, 1D and 2D
- Classes and Objects

EXAM TOPICS

- Programming process: write, compile execute
- Variables
- Type
- Conditionals: if, else statements
- Boolean operations
- Loops: while and for
- Methods
- CS coordinate system
- Generating random numbers
- Arrays, 1D and 2D
- Classes and Objects

EXAM TOPICS CONT

- Interactivity, using mouse and keyboard input in your programs
- Debugging: identifying and fixing common errors
- Recursion
- L-Systems
- Cellular Automata
- Importing and parsing data from files
- Plotting data

**PRACTICE FINAL ON LEARN
USE THIS +
MIDTERM
PRACTICE MIDTERM
QUIZZES
TO STUDY**

questions?

ACCESSING PREVIOUS QUIZZES & FEEDBACK ON LEARN

NAVIGATE TO My Grades

The screenshot displays a user interface for a course management system. On the left, a sidebar menu is visible under the heading "CS-152L - Fall 2021 Section Group JNO". The menu items include "Course Information", "Create a Support Ticket", "Assignments", "My Grades" (highlighted with a pink circle), "Quizzes", "Exams", and "How to Use Learn". The main content area is titled "My Grades" and features a filter bar with options: "All", "Graded" (selected), "Upcoming", and "Submitted". Below the filter bar, the page lists graded items under the heading "ITEM". The first item is "Assignment 1: Short essay: What excites you about computing?", with a due date of "AUG 30, 2021" and a link to "View Rubric". The second item is "Quiz 2", with a due date of "OCT 2, 2021" and a link to "View Description". A "Midterm Assignment Average" section is also visible at the bottom of the list.

CLICK ON AN ITEM TO OPEN IT

The image shows a screenshot of a course management system interface. On the left is a sidebar menu for the course 'CS-152L - Fall 2021 Section Group JNO'. The menu items are: Course Information, Create a Support Ticket, Assignments, My Grades, Quizzes, Exams, and How to Use Learn. The 'My Grades' item is highlighted. On the right is the 'My Grades' page, which has tabs for 'All', 'Graded', 'Upcoming', and 'Submitted'. The 'Graded' tab is selected. Below the tabs, there is a list of items. The first item is 'Assignment 1: Short essay: What excites you about computing?' with a due date of 'AUG 30, 2021'. The second item is 'Quiz 2' with a due date of 'OCT 2, 2021'. The 'Quiz 2' item is circled in red. The third item is 'Midterm Assignment Average' with a 'View Description' link.

**CS-152L - Fall 2021
Section Group JNO**

- Course Information
- Create a Support Ticket
- Assignments
- My Grades**
- Quizzes
- Exams
- How to Use Learn

My Grades

All Graded Upcoming Submitted

ITEM

Assignment 1: Short essay: What excites you about computing?
DUE: AUG 30, 2021
Assignment
[View Rubric](#)

Quiz 2
DUE: OCT 2, 2021
Test

Midterm Assignment Average
[View Description](#)

CLICK ON YOUR SCORE

CS-152L - Fall 2021
Section Group JNO

Course Information
Create a Support Ticket

Assignments

My Grades
Quizzes
Exams
How to Use Learn

View Attempts

ASSESSMENT DETAILS

Item Name	Quiz 2
Aggregation	Last attempt
Due Date	10/2/21
Points Possible	50

ATTEMPTS

Date Created	Date Last Submitted or Edited	Calculated Grade
Dec 5, 2021 1:37 PM	Dec 5, 2021 1:38 PM LATE	15.00

Icon Legend

REVIEW YOUR SUBMISSION

Review Test Submission: Quiz 2

User	Demo User
Course	CS-152L - Fall 2021 Section Group JNO
Test	Quiz 2
Started	12/5/21 1:37 PM LATE
Submitted	12/5/21 1:38 PM LATE
Due Date	10/2/21 11:00 AM
Status	Completed
Attempt Score	15 out of 50 points
Time Elapsed	0 minute out of 2 hours
Results Displayed	All Answers, Submitted Answers, Correct Answers, Feedback, Incorrectly Answered Questions

Question 1

5 out of 5 points



Based on the following code:

```
int[] myArray = new int[ 10];  
for (int i=0; i<myArray.length; i++) {  
    myArray[i] = i*2;  
}
```

What is the value of myArray[3]?

Selected Answer: 6

Answers: 3

myArray[3] has no value because the array was never created

6

myArray[3] has no value because the index is outside the length of myArray

questions?

REVIEW

WORKING THROUGH QUIZ 1

questions?

WORKING THROUGH QUIZ 2

questions?

**GOING OVER TOPICS
FROM THE BEGINNING**

ELEMENTS OF A COMPUTER

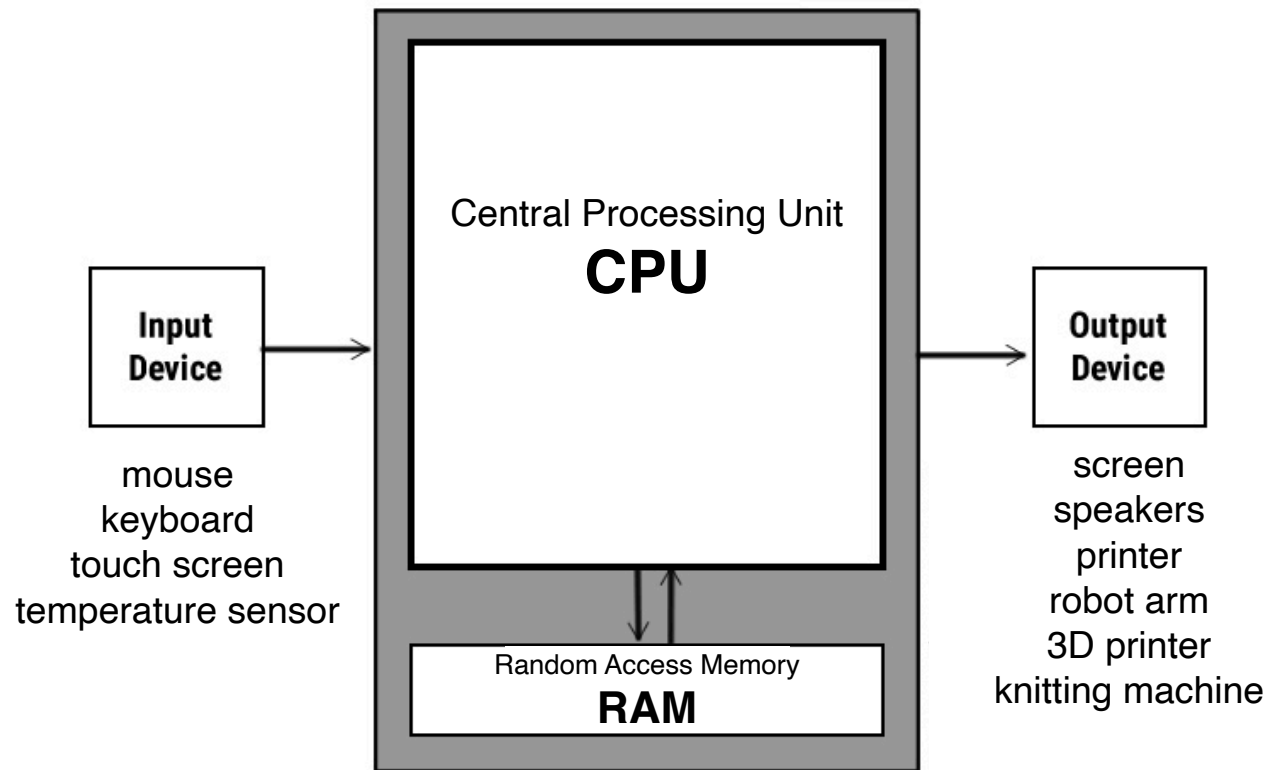

PROGRAMMING PROCESS

1. Write “source” code
2. Compile code
 - Compiler translates code written in high level language into “byte” code that a computer understands
 - Code with “syntax” errors will not compile
 - Syntax error = programming version of spelling and punctuation mistakes
3. Execute code
 - Computer runs or “executes” byte code
 - Turns written instructions into behavior!

VARIABLES

variable's type

```
int rectWidth = 200;
```

int = integer

a whole number

variable's name

```
int rectWidth = 200;
```

variable's value

```
int rectWidth = 200;
```

```
int rectWidth;  
rectWidth = 200;
```

can also define a variable on one line
and assign a value to it later

TYPE

WHAT IS TYPE?

tells the computer how much memory
a variable takes up +
what it can do with the variable

BASIC NUMBER TYPES IN JAVA

TYPE	# BITS	minimum value	maximum value	example
byte	8	-128	127	53
int	32	-2,147,483,648	2,147,483,647	3079
float	32	$\sim -3.4 \times 10^{38}$ with 7 significant digits	$\sim 3.4 \times 10^{38}$ with 7 significant digits	4.589

MORE NUMBER TYPES IN JAVA

TYPE	# BITS	minimum value	maximum value	example
short	16	-32,768	32,767	134
long	64	$\sim -9.2 \times 10^{18}$	$\sim 9.2 \times 10^{18}$	30,790
double	64	$\sim -1.7 \times 10^{308}$ with 15 significant digits	$\sim 1.7 \times 10^{308}$ with 15 significant digits	10,789.998

OTHER “PRIMITIVE” TYPES IN JAVA

TYPE	# BITS	# possible values	examples
char	16	65,536	'A' 'c' '?'
boolean	1	2	true false

PRIMITIVE TYPE

cannot be broken down into a simpler type

MORE COMPLEX TYPES ARE COLLECTIONS OF THINGS

TYPE	collection of	example
String	chars	<code>String s = "hello";</code>
arrays	many items of a single type	<code>int[] n = {1,2,3};</code> <code>char[] c = {'a','b','c'};</code>
Color	numbers that define a color	<code>Color c = new Color(50,0,100);</code>

questions?

CONDITIONALS

IF STATEMENT

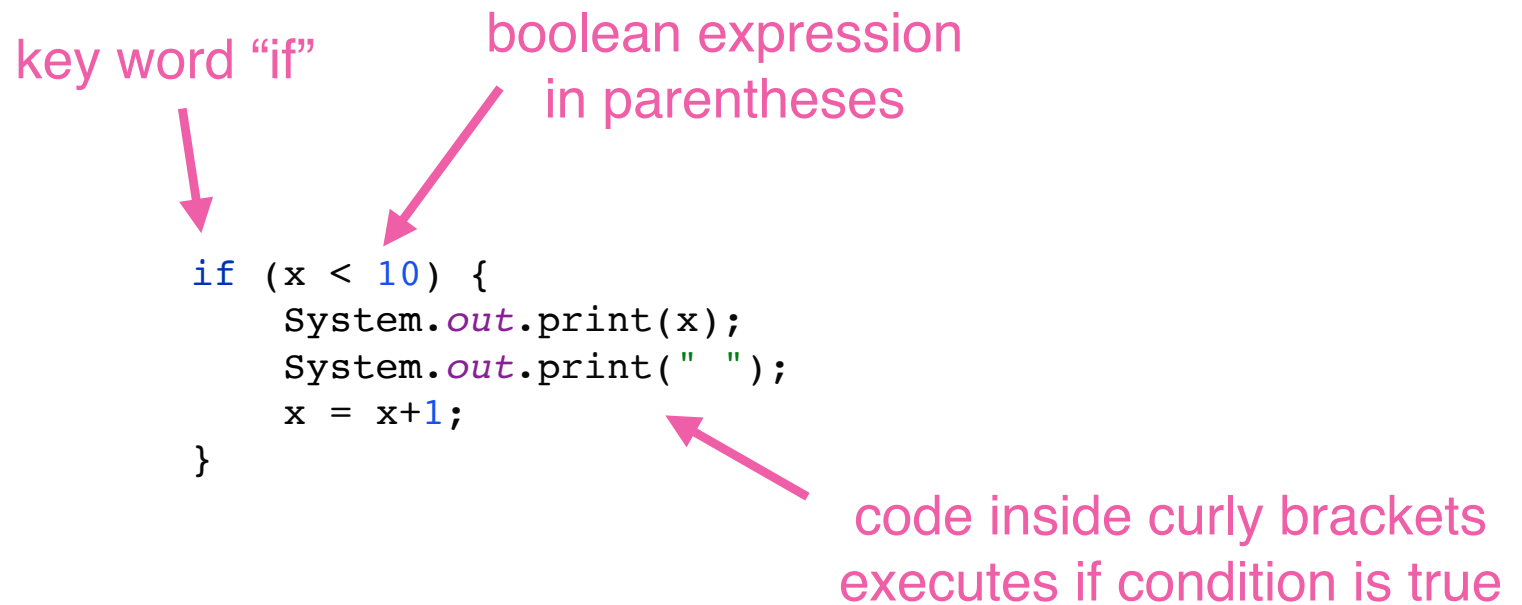

IF ELSE STATEMENT

key word "if"

boolean expression
in parentheses

```
if (x < 10) {  
    System.out.print(x);  
    System.out.print(" ");  
    x = x+1;  
}  
else {  
    System.out.println(x);  
}
```

key word "else"

code inside curly brackets
executes if condition is false

BOOLEAN EXPRESSIONS

- A question with an answer that is either TRUE or FALSE
- A logical statement that is either TRUE or FALSE
- Examples:

`y != 4000`

Is y not equal to 4000?

`x <= 50`

Is x less than or equal to 50?

`a == 10.5`

Is a equal to 10.5?

RELATIONAL OPERATORS

- Relational operators ask about the relationships between things. They ask our questions. They are:

<code>==</code>	equal to	<code>x == 10</code>	is x equal to 10?
<code>!=</code>	NOT equal to	<code>x != 10</code>	is x not equal to 10?
<code><</code>	less than	<code>x < 10</code>	is x less than 10?
<code><=</code>	less than or equal to	<code>x <= 10</code>	is x less than or equal to 10?
<code>></code>	greater than	<code>x > 10</code>	is x greater than 10?
<code>>=</code>	greater than or equal to	<code>x >= 10</code>	is x greater than or equal to 10?

BOOLEAN EXPRESSIONS

- Create more complex expressions by combining them with AND and OR
 - » AND `&&` combines 2 statements, TRUE if both are TRUE
 - » OR `||` combines 2 statements, TRUE if either is TRUE
- Examples
 - » `mouseY < 250 && mouseX < 250`
(is mouseY less than 250 and mouseX less than 100?)
 - » `x == 0 || x == 5`
(is x equal to 0 or 5?)
 - » `(mouseY < 250 && mouseX < 250) || (x != 7)`

questions?